

2835R Series



Standard 2835 package to address retrofit applications

2835R Series is a complementary portfolio with optimized performance and bin construction for the retrofit space. With an industry standard footprint, it provides the perfect balance between performance and cost efficiency for a variety of applications.

FEATURES AND BENEFITS

Flexible voltage configurations to comply with various different system solutions

Industry standard footprint for drop-in replacement designs

High maximum drive current to allow for reduction of LED count

Part Number Nomenclature

Part numbers for the 2835R Series follow the convention below:

L 1 2 8 – A A B B R C 3 5 0 0 D D D

Where:

A A - designates nominal CCT (27=2700K, 30=3000K, 35=3500K, 40=4000K, 50=5000K, 57=5700K, 65=6500K)

B B - designates nominal CRI (70=70CRI, 75=75CRI, 80=80CRI and 90=90CRI)

C - designates voltage (A=3V, B=6V, C=9V, G=12V, D=18V, E=36V, F=54V)

D D D - designates Lumileds internal code (0A1, 0B1, 0C1, etc.=shares the same base part)

Therefore, the following part number is used for a 2835R 3000K, 80CRI, 36V LED:

L 1 2 8 – 3 0 8 0 R E 3 5 0 0 0 A 1

Lumen Maintenance

Please contact your local Sales Representative or Lumileds Technical Solutions Manager for more information about the long- term performance of this product.

Environmental Compliance

Lumileds LLC is committed to providing environmentally friendly products to the solid-state lighting market. The 2835R Series is compliant to the European Union directives on the restriction of hazardous substances in electronic equipment, namely the RoHS Directive 2011/65/EU and REACH Regulation (EC) 1907/2006. Lumileds LLC will not intentionally add the following restricted materials to its products: lead, mercury, cadmium, hexavalent chromium, polybrominated biphenyls (PBB) or polybrominated diphenyl ethers (PBDE).

Mass Production List of 2835R Series

Product	Product Number	CCT	Ra Min	Φ (lm) Min	Φ (lm) Typ	Φ (lm) Max	Test conditions
2835R 3V	L128-2780RC35001H3	2700	80	135	140	150	25°C, IF=150mA
	L128-3080RC35001H3	3000	80	140	145	155	
	L128-4080RC35001H3	4000	80	150	155	165	
	L128-2780RC35001H3	5000	80	150	155	165	
	L128-6580RC35001H3	6500	80	150	155	165	

Notes:

- 1.Tolerance of Color Rendering Index: ± 2 .
- 2.Tolerance of Luminous flux: $\pm 5\%$.

Absolute maximum ratings($T_a=25^\circ\text{C}$)

Parameter	Symbol	Value	Unit
Power dissipation	Pd	1128	mW
Forward current	IF	120	mA
Operating temperature range	Top	-40~+100	°C
Storage temperature range	Tstg	-40~+100	°C
Heatresistance	Rth	25	°C/W
Junction temperature	Tj	125	°C
Electrostatic Discharge	ESD	2000	V

Electro-optical characteristics(Ta=25°C)

Parameter	Symbol	Min	Typ	Max	Unit	Test Condition
Forward voltage	Vf	8.6	-	9.4	V	IF=150mA
Viewing Angle	2 θ 1/2	-	120	-	Deg	IF=150mA
Luminous flux	Φ	135	-	-	lm	IF=150mA
Reverse current	IR	-	-	10	μA	VR=5V
Color Index	Ra	80	-	-	-	IF=150mA

NOTES:

- * The measurement of forward voltage maintains a tolerance of $\pm 0.05V$, flux maintains a tolerance of $\pm 5\%$.
- * Ra measurement tolerance is ± 2 .
- * Rth j-sp is the thermal resistance from LED junction to solder point on MCPCB with electrical power.
- * the product is not designed to be used under reverse voltage.

Reliability Test Items And Conditions

Test Items	Test condition	Time	Quantity	Ac/Re
Reflow Soldering	Temp. :260°C/10sec.	6Min.	22pcs	0/22
Thermal Shock	-40~125C, 15min dwell, 10sec transfer	100Cycles	22pcs	0/22
High Temperature High Humidity life Test	85°C,85%RH, IF=100mA	1000Hrs.	10pcs	0/10
Low Temperature Storage	Ta=-40°C	1000Hrs.	10pcs	0/10
High Temperature Storage	Ta=105°C	1000Hrs.	10pcs	0/10
High Temperature Operation Life Test	Ta=85°C, IF =100mA.	1000Hrs.	10pcs	0/10

Failure Criteria

Item	Symbol	Failure Criteria
Luminous Flux	Lm	$\geq 70\%$
Forward voltage	VF	$\pm 10\%$
Colour	CIE_X CIE_y	± 0.01

Typical optical characteristics curves

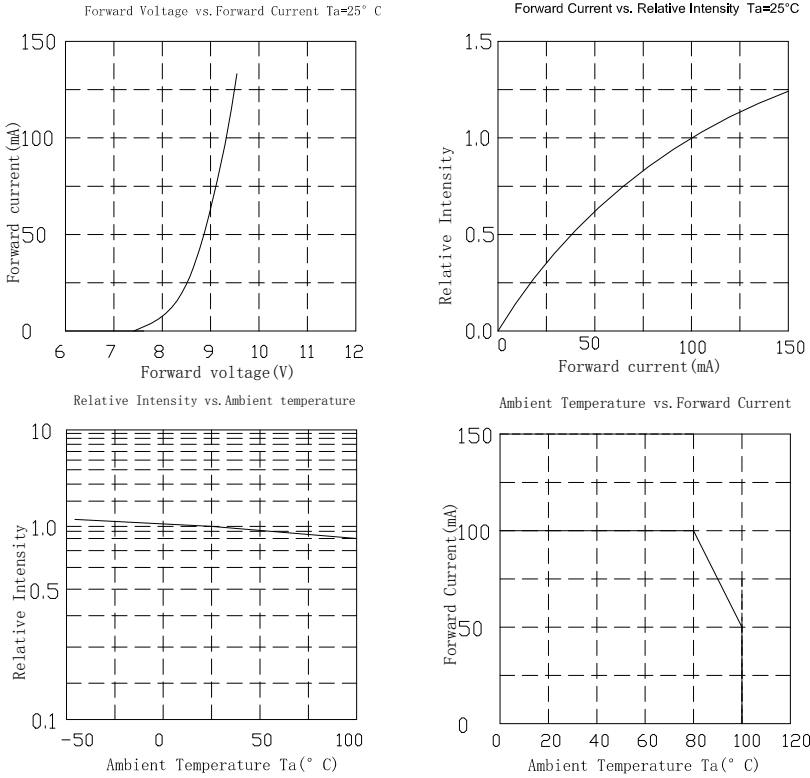

Curves of beam angle and relative brightness

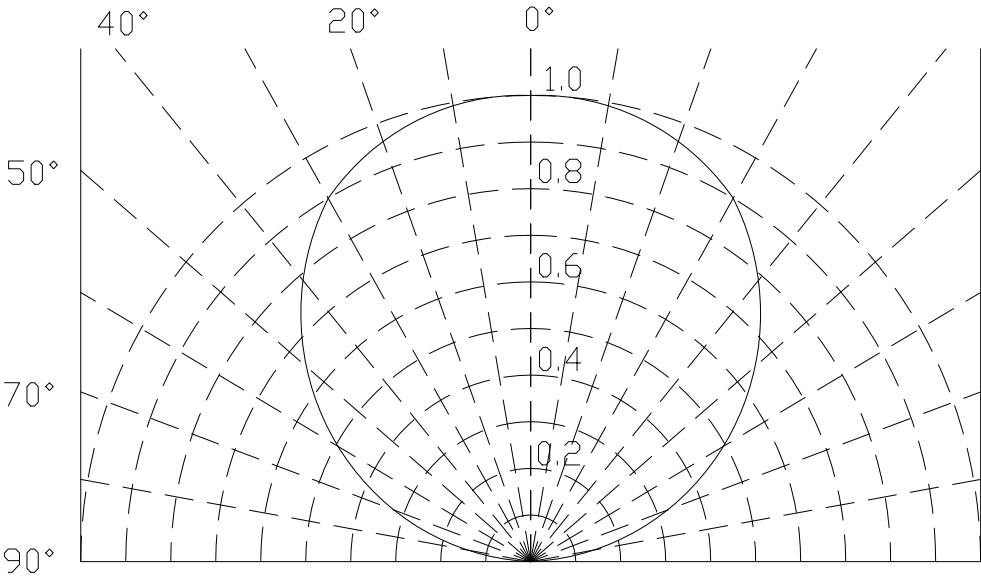

life test:

Affect of T_j on Luminous Maintenance
 ($I_f=100\text{mA}$)
 (Dot line: Expected Life)

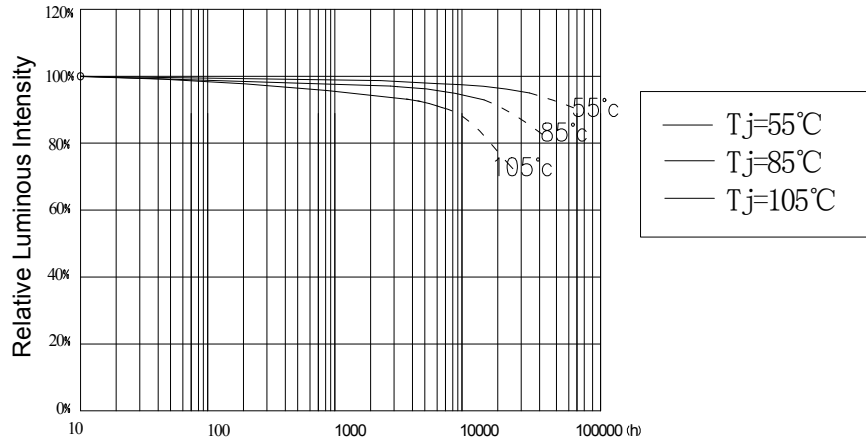

Mechanical Dimensions: Unit (mm)

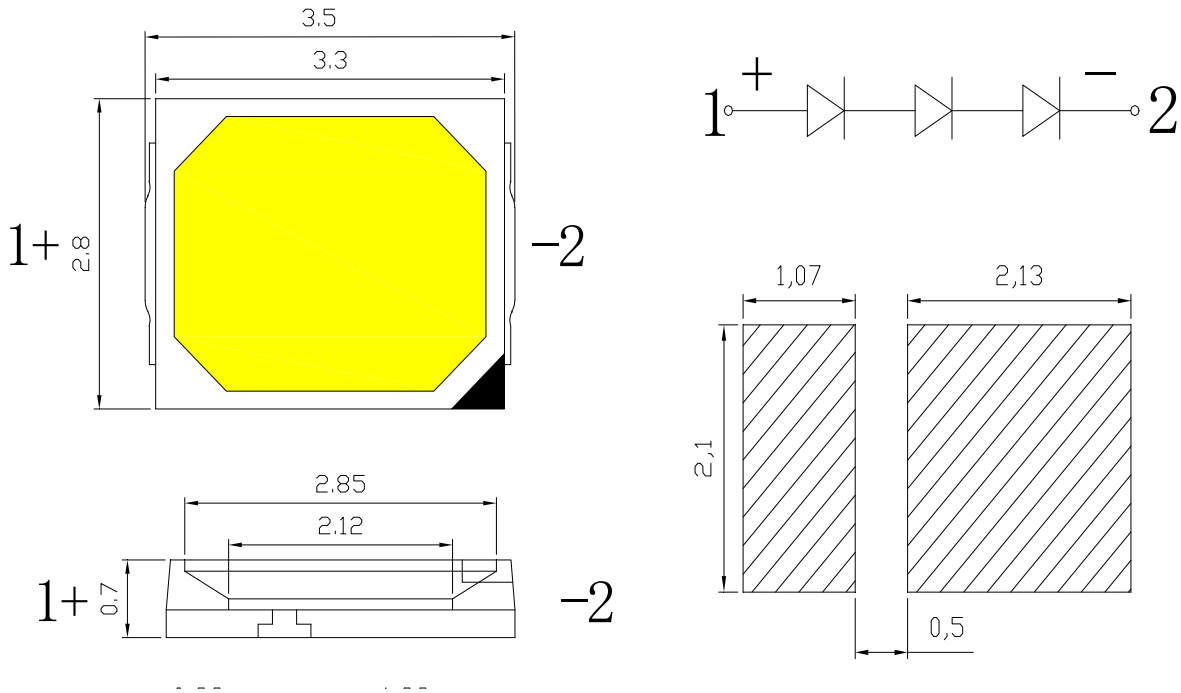

Product Bin and Labeling Definitions

Decoding Product Bin Labeling

In the manufacturing of semiconductor products, there are variations in performance around the average values given in the technical datasheet. For this reason, Lumileds bins LED components for luminous flux or radiometric power, color point, peak or dominant wavelength and forward voltage.

2835R Series LEDs are labeled using a 5-digit alphanumeric CAT code following the format below

Where:

A B C D E

A - designates luminous flux bin (example: B=95 to 100 lumens, G=140 to 150 lumens)

B C D - designates correlated color bin (example: A27, A30, A35, A40, A50, A57, A65)

E - designates forward voltage bin (example: B=34.5 to 35.0V, J=38.0 to 38.5V)

Therefore, a 2835R LED with a lumen range of 95 to 100, color bin of A35 and a forward voltage range of 38.0 to 38.5V has the following CAT code:

B A 3 5 J

Luminous Flux Bins

Luminous flux bin definitions for 2835R Series at rated current, Ta=25°C .

Product Number	Bin	Min	Max
L128-xx80RC35001H3	F1	130	135
	F2	135	140
	G1	140	145
	G2	145	150
	H1	150	155
	H2	155	160
	I1	160	165
	I2	165	170

Notes

Lumileds Maintains a tolerance of $\pm 5\%$ on lumionous flux measurements

Forward Voltage Bins

Forward voltage bin definitions for 2835R Series at rated current, Ta=25°C .

Product Number	Bin	Min	Max
L128-xx80RC35001H3	A	8.6	8.8
	B	8.8	9.0
	C	9.0	9.2
	D	9.2	9.4

Color Bin Definition

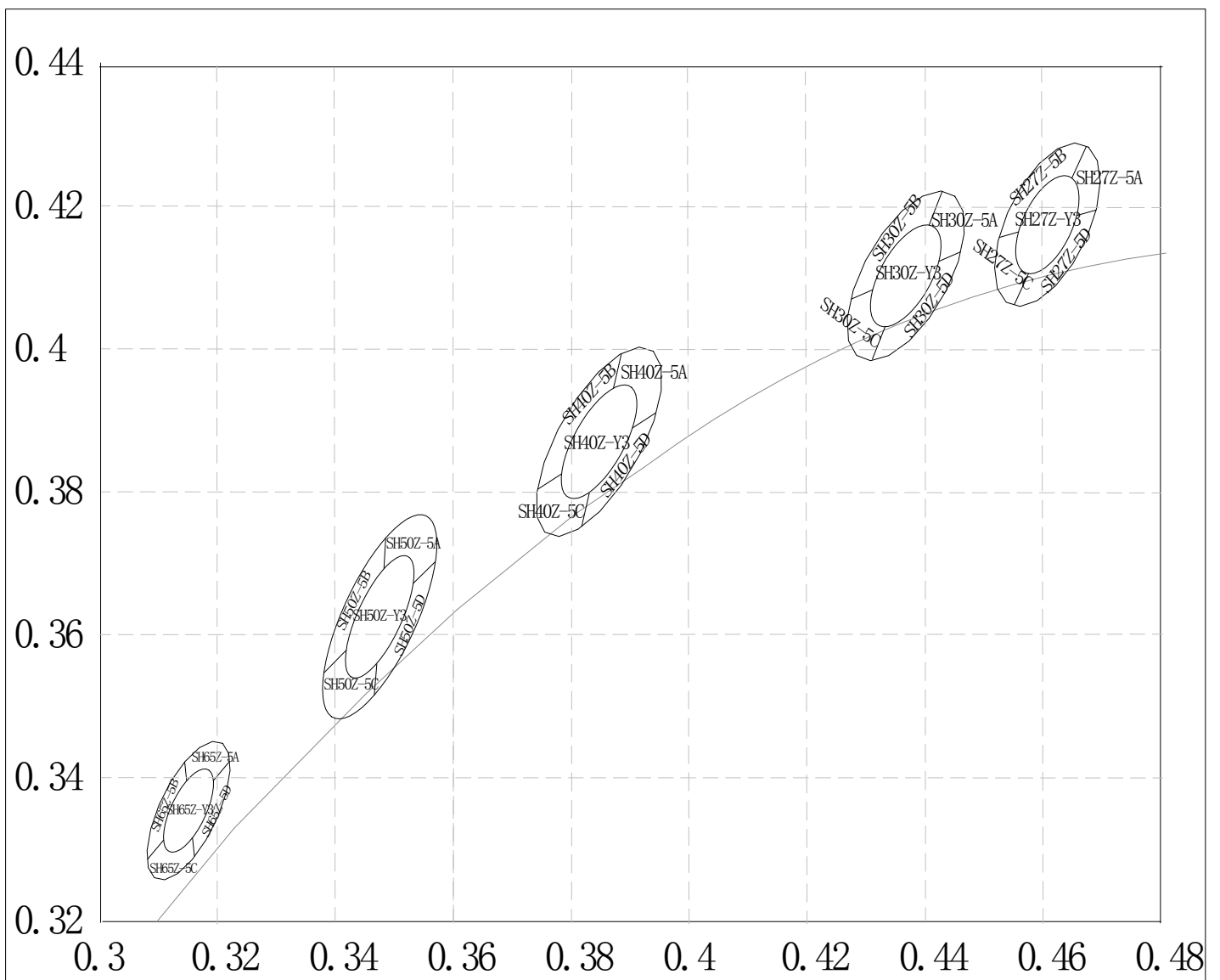

Correlated color temperature bin definitions for 2835R Series at rated current, Ta=25°C

CCT	Color space	Center X	Center Y	a	b	Rotation Angle
2700K	3-Step	0.4606	0.4173	0.0077	0.004	57.28
	5-Step	0.4606	0.4173	0.0129	0.0067	57.28
3000K	3-Step	0.4366	0.4102	0.008346	0.004098	53.16
	5-Step	0.4366	0.4102	0.01391	0.006831	53.16
4000K	3-Step	0.3846	0.3869	0.009386	0.004035	54
	5-Step	0.3846	0.3869	0.015644	0.006725	54
5000K	3-Step	0.3475	0.3625	0.00971	0.0036	59.62
	5-Step	0.3475	0.3625	0.016183	0.006	59.62
6500K	3-Step	0.3151	0.3354	0.006617	0.002855	58.38
	5-Step	0.3151	0.3354	0.011029	0.004758	58.38

bin Colde	SH27Z-Y3/5A/B/C/D		SH30Z-Y3/5A/B/C/D		SH40Z-Y3/5A/B/C/D		SH50Z-Y3/5A/B/C/D		SH65Z-Y3/5A/B/C/D	
CCT	2700K		3000K		4000K		5000K		6500K	
#	x	y	x	y	x	y	x	y	x	y
1	0.4841	0.4391	0.459	0.4332	0.4033	0.4116	0.3615	0.3865	0.3234	0.3554
2	0.4716	0.4362	0.4459	0.4285	0.3894	0.4027	0.3488	0.3760	0.314	0.346
3	0.459	0.4332	0.4327	0.4237	0.3754	0.3938	0.3361	0.3656	0.3046	0.3366
4	0.4496	0.4149	0.4251	0.4062	0.3721	0.3791	0.3359	0.3531	0.3066	0.3271
5	0.4401	0.3965	0.4175	0.3886	0.3688	0.3644	0.3357	0.3406	0.3087	0.3176
6	0.4511	0.3991	0.4288	0.3926	0.3807	0.3716	0.3463	0.3489	0.3166	0.3253
7	0.4621	0.4016	0.4401	0.3965	0.3925	0.3788	0.3569	0.3573	0.3249	0.3333
8	0.4731	0.4204	0.4496	0.4149	0.3971	0.3925	0.3592	0.3723	0.3241	0.3443

Notes

Tester tolerance: ±0.01 in x and y coordinates

Requirements for application and reflow soldering :

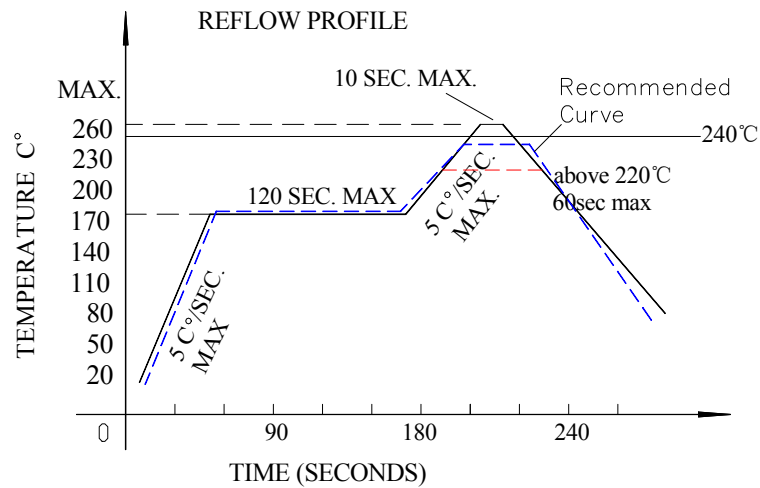

■ Notes for reflow soldering :

1. No more than twice for reflow soldering.
2. To ensure the quality of our LEDs, we encapsulate them with silica gels. So please do not put pressure on the LEDs.
3. Please choose the right nozzle(try to learn from the plastic products parts) to avoid the damage to products due to the pressure.
4. Please put on the antistatic hand loop during the use. The worktable should be with antistatic finish. The equipments must be contacted with ground.

■ Handwork soldering:

1. During the soldering, the electronic soldering iron must be kept under the temperature of 300°C and the soldering time must not be beyond 3 seconds. No touch between the electronic soldering iron and colloid.
2. Handwork soldering is only allowed once. We won't take responsibility for more than that.
3. Avoid using sharp objects to compress products Colloidal Part directly.
4. Please put on the antistatic hand loop during the use. The worktable should be with antistatic finish. The equipments must be contacted with ground.