

2835R Series



Standard 2835 package to address retrofit applications

2835R Series is a complementary portfolio with optimized performance and bin construction for the retrofit space. With an industry standard footprint, it provides the perfect balance between performance and cost efficiency for a variety of applications.

FEATURES AND BENEFITS

Flexible voltage configurations to comply with various different system solutions

Industry standard footprint for drop-in replacement designs

High maximum drive current to allow for reduction of LED count

Part Number Nomenclature

Part numbers for the 2835R Series follow the convention below:

L 1 2 8 – A A B B R C 3 5 0 0 D D D

Where:

A A - designates nominal CCT (27=2700K, 30=3000K, 35=3500K, 40=4000K, 50=5000K, 57=5700K, 65=6500K)

B B - designates nominal CRI (70=70CRI, 75=75CRI, 80=80CRI and 90=90CRI)

C - designates voltage (A=3V, B=6V, C=9V, G=12V, D=18V, E=36V)

D D D - designates Lumileds internal code (0A1, 0B1, 0C1, etc.=shares the same base part)

Therefore, the following part number is used for a 2835R 3000K, 80CRI, 36V LED:

L 1 2 8 – 3 0 8 0 R E 3 5 0 0 0 A 1

Lumen Maintenance

Please contact your local Sales Representative or Lumileds Technical Solutions Manager for more information about the long- term performance of this product.

Environmental Compliance

Lumileds LLC is committed to providing environmentally friendly products to the solid-state lighting market. The 2835R Series is compliant to the European Union directives on the restriction of hazardous substances in electronic equipment, namely the RoHS Directive 2011/65/EU and REACH Regulation (EC) 1907/2006. Lumileds LLC will not intentionally add the following restricted materials to its products: lead, mercury, cadmium, hexavalent chromium, polybrominated biphenyls (PBB) or polybrominated diphenyl ethers (PBDE).

Mass Production List of 2835R Series

Product	Product Number	CCT	Ra Min	Φ(lm) Min	Φ(lm) Typ	Φ(lm) Max	Test conditions
2835R 9V	L128-2770RC35001A1	2700	70	138	143	-	25°C, IF=100mA
	L128-3070RC35001A1	3000	70	145	150	-	
	L128-3570RC35001A1	3500	70	146	151	-	
	L128-4070RC35001A1	4000	70	150	156		
	L128-5070RC35001A1	5000	70	150	156		
	L128-5770RC35001A1	5700	70	150	156		
	L128-6570RC35001A1	6500	70	150	156		

Notes:

- 1.Tolerance of Color Rendering Index: ± 2 .
- 2.Tolerance of Luminous flux: $\pm 5\%$.

Absolute maximum ratings(Ta=25°C)

Parameter	Symbol	Value	Unit
Power dissipation	Pd	1128	mW
Forward current	IF	120	mA
Reverse voltage	VR	15	V
Operating temperature range	Top	-40 ~+100	°C
Storage temperature range	Tstg	-40 ~+100	°C
Heatresistance	Rth	15	°C
Junction temperature	Tj	125	°C
Electrostatic Discharge	ESD	2000	V

Electro-optical characteristics(Ta=25°C)

Parameter	Symbol	Min	Typ	Max	Unit	Test Condition
Forward voltage	Vf	8.6		9.4	V	IF=100mA
Luminous flux	Φ	138			lm	IF=100mA
Viewing Angle	2 θ 1/2		120		Deg	IF=100mA
Reverse current	IR			10	μA	Vr=15V
Color Index	Ra	70				IF=100mA

NOTES:

- * The measurement of forward voltage maintains a tolerance of $\pm 0.05V$, flux maintains a tolerance of $\pm 5\%$.
- * Ra measurement tolerance is ± 2 .
- * Rth j-sp is the thermal resistance from LED junction to solder point on MCPCB with electrical power.

Reliability Test Items And Conditions

Test Items	Test condition	Time	Quantity	Ac/Re
Reflow Soldering	Temp. :260°C/10sec.	6Min.	22pcs	0/22
Thermal Shock	-40~125C, 15min dwell, 10sec transfer	100Cycles	22pcs	0/22
High Temperature High Humidity life Test	85°C,85%RH, IF=100mA	1000Hrs.	10pcs	0/10
Low Temperature Storage	Ta=-40°C	1000Hrs.	10pcs	0/10
High Temperature Storage	Ta=100°C	1000Hrs.	10pcs	0/10
High Temperature Operation Life Test	Ta=85°C, IF =100mA.	1000Hrs.	10pcs	0/10

Failure Criteria

Item	Symbol	Failure Criteria
Luminous Flux	Lm	$\geq 70\%$
Forward voltage	VF	$\pm 10\%$
Colour	CIE_X CIE_y	± 0.01

Typical optical characteristics curves

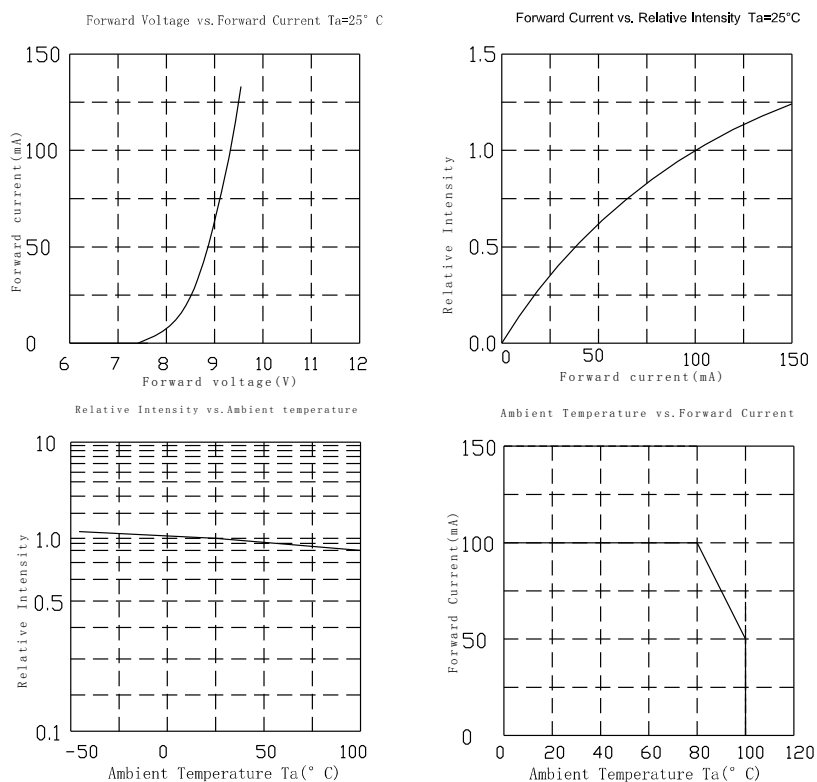

Curves of beam angle and relative brightness

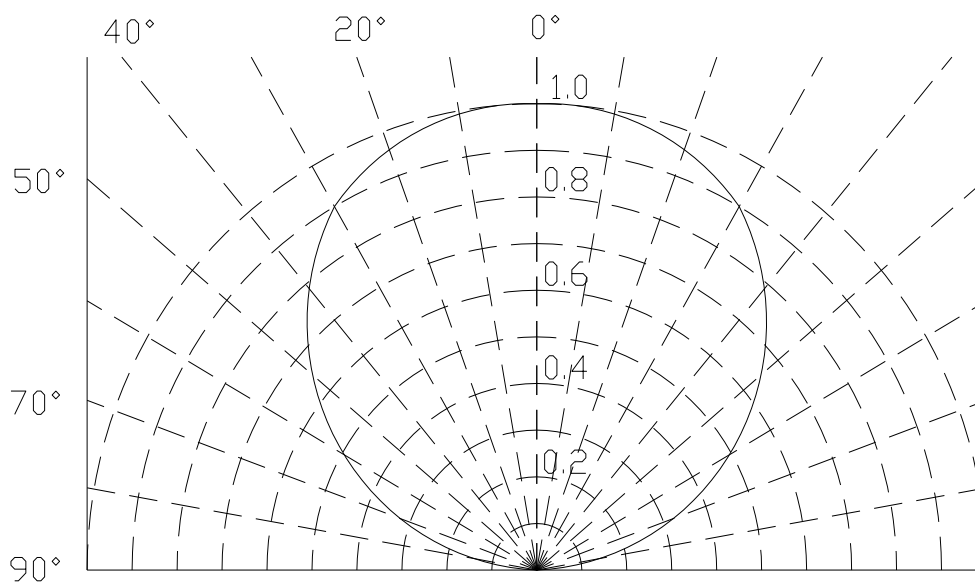

life test:

Affect of Tj on Luminous Maintenance

(If=100mA)

(Dot line: Expected Life)

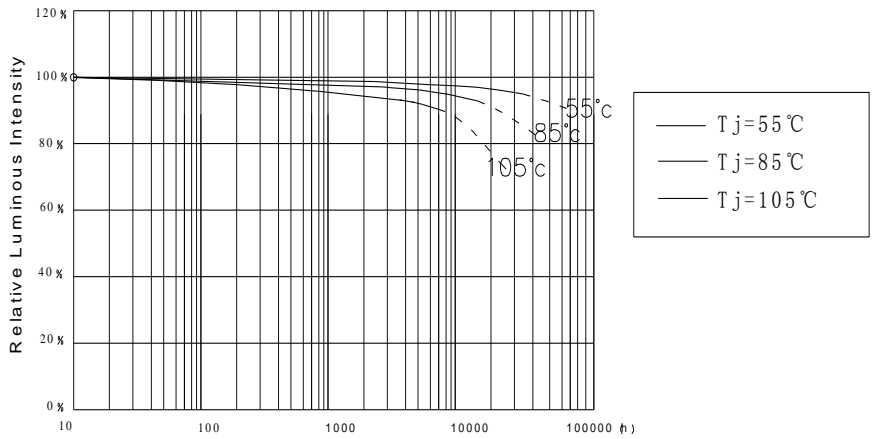

mechanical Dimensions: Unit (mm)

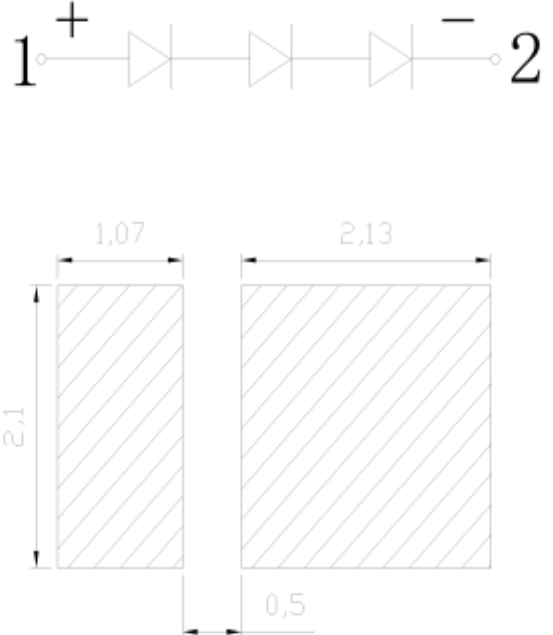
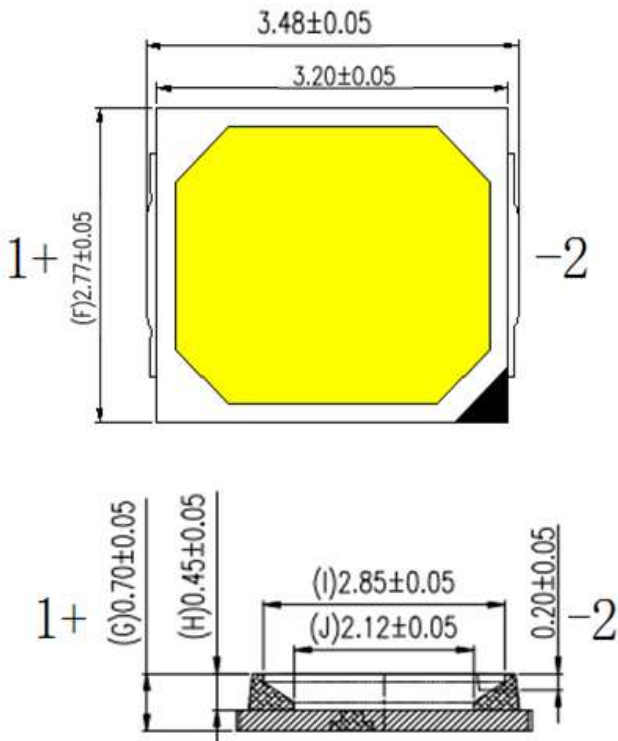

For reflow soldering

Product Bin and Labeling Definitions

Decoding Product Bin Labeling

In the manufacturing of semiconductor products, there are variations in performance around the average values given in the technical datasheet. For this reason, Lumileds bins LED components for luminous flux or radiometric power, color point, peak or dominant wavelength and forward voltage.

2835R Series LEDs are labeled using a 5-digit alphanumeric CAT code following the format below

Where:

A B C D E

A - designates luminous flux bin (example: B=95 to 100 lumens, G=140 to 150 lumens)

B C D - designates correlated color bin (example: A27, A30, A35, A40, A50, A57, A65) ,

It does not restrict the number of digits or the name

E - designates forward voltage bin (example: B=34.5 to 35.0V, J=38.0 to 38.5V)

Therefore, a 2835R LED with a lumen range of 95 to 100, color bin of A35 and a forward voltage range of 38.0 to 38.5V has the following CAT code:

B A 3 5 J

Luminous Flux Bins

Luminous flux bin definitions for 2835R Series at rated current, $T_a=25^{\circ}\text{C}$.

Product Number	Bin	Min	Max
L128-xx70RC35001A1	F	130	140
	G	140	150
	H	150	160
	J	160	170
	K	170	180

Notes

Lumileds Maintains a tolerance of $\pm 5\%$ on lumionous flux measurements

Forward Voltage Bins

Forward voltage bin definitions for 2835R Series at rated current, $T_j=25^{\circ}\text{C}$.

Product Number	Bin	Min	Max
L128-xx70RC35001A1	A	8.6	8.8
	B	8.8	9.0
	C	9.0	9.2
	D	9.2	9.4

Color Bin Definition

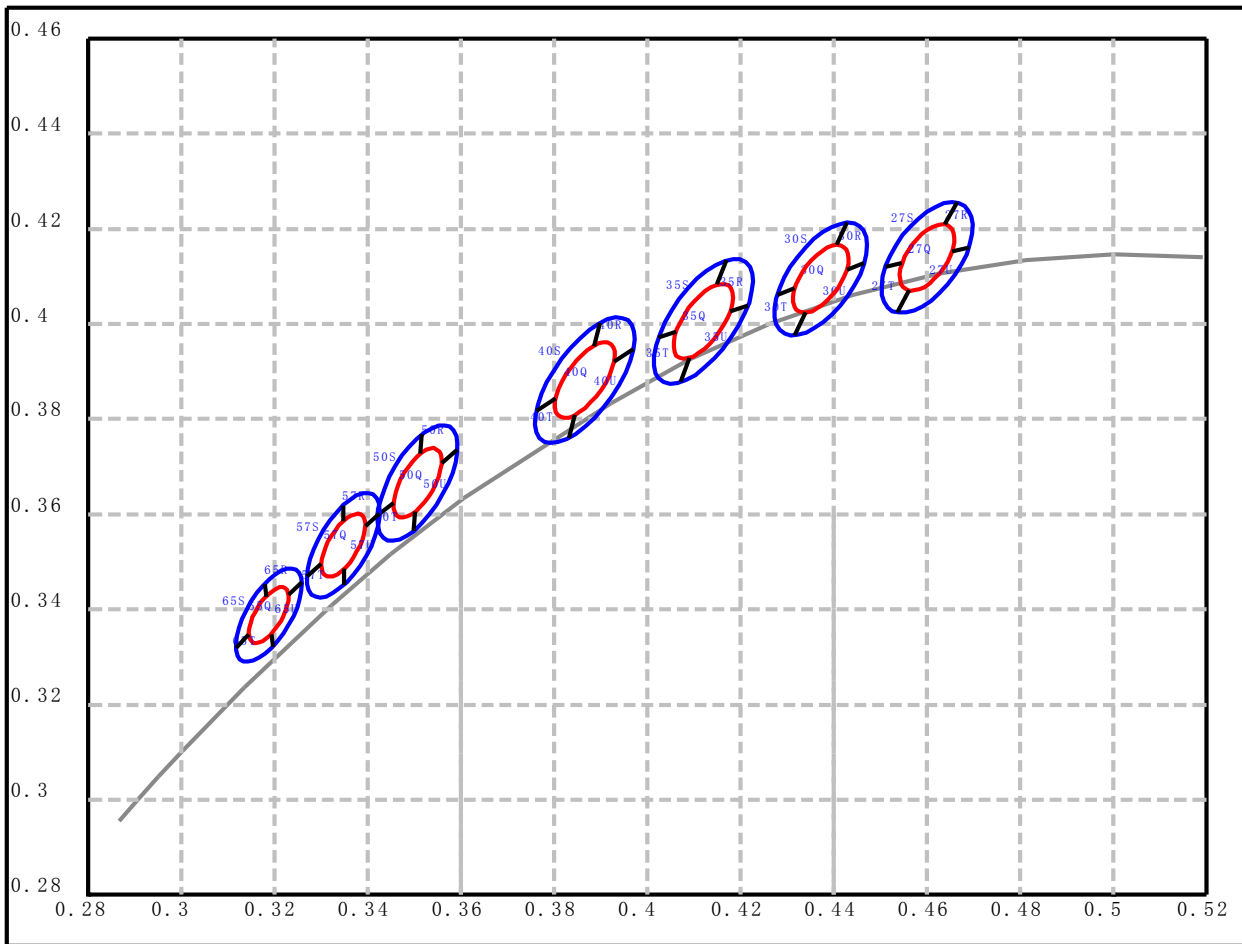

Correlated color temperature bin definitions for 2835R Series at rated current, Ta=25°C

CCT	Color space	Center X	Center Y	a	b	Rotation Angle
2700K	3-Step	0.46	0.414	0.0081	0.0042	53.7
	5-Step	0.46	0.414	0.0135	0.007	53.7
3000K	3-Step	0.4372	0.4095	0.00834	0.00408	53.22
	5-Step	0.4372	0.4095	0.0139	0.0068	53.22
3500K	3-Step	0.412	0.4006	0.00927	0.00414	54
	5-Step	0.412	0.4006	0.01545	0.0069	54
4000K	3-Step	0.3866	0.3882	0.00939	0.00402	53.72
	5-Step	0.3866	0.3882	0.01565	0.0067	53.72
5000K	3-Step	0.3507	0.3666	0.00822	0.00354	59.62
	5-Step	0.3507	0.3666	0.0137	0.0059	59.62
5700K	3-Step	0.3348	0.3535	0.00746	0.0032	59.09
	5-Step	0.3348	0.3535	0.01243	0.00533	59.09
6500K	3-Step	0.3188	0.3388	0.00669	0.00285	58.57
	5-Step	0.3188	0.3388	0.01115	0.00475	58.57

bin Code	27Q/R/S/T/U		30Q/R/S/T/U		35Q/R/S/T/U		40Q/R/S/T/U	
CCT	2700K		3000K		3500K		4000K	
#	x	y	x	y	x	y	x	y
1	0.469	0.4161	0.4465	0.4127	0.4216	0.404	0.3971	0.3947
2	0.4664	0.4256	0.4429	0.4213	0.4169	0.4134	0.3899	0.4003
3	0.451	0.4119	0.4279	0.4062	0.4023	0.3971	0.3762	0.3818
4	0.4536	0.4024	0.4316	0.3977	0.4071	0.3878	0.3832	0.3761
5	0.4654	0.4153	0.4428	0.4114	0.4178	0.4026	0.3929	0.3921
6	0.4638	0.4209	0.4406	0.4166	0.4149	0.4083	0.3886	0.3954
7	0.4546	0.4128	0.4316	0.4075	0.4062	0.3985	0.3803	0.3844
8	0.4562	0.4071	0.4339	0.4024	0.4091	0.3929	0.3845	0.3809
bin Code	50Q/R/S/T/U		57Q/R/S/T/U		65Q/R/S/T/U			
CCT	5000K		5700K		6500K			
#	x	y	x	y	x	y		
1	0.3593	0.3736	0.3426	0.3601	0.3259	0.3458		
2	0.3517	0.3768	0.3347	0.3619	0.3179	0.3454		
3	0.3421	0.3597	0.327	0.3469	0.3117	0.3319		
4	0.3499	0.3565	0.335	0.3452	0.3197	0.3322		
5	0.3558	0.3708	0.3395	0.3575	0.323	0.343		
6	0.3513	0.3727	0.3348	0.3586	0.3183	0.3428		
7	0.3456	0.3625	0.3301	0.3495	0.3146	0.3347		
8	0.3502	0.3605	0.3349	0.3485	0.3193	0.3348		

Notes

Tester tolerance: ± 0.01 in x and y coordinates

Requirements for application and reflow soldering :

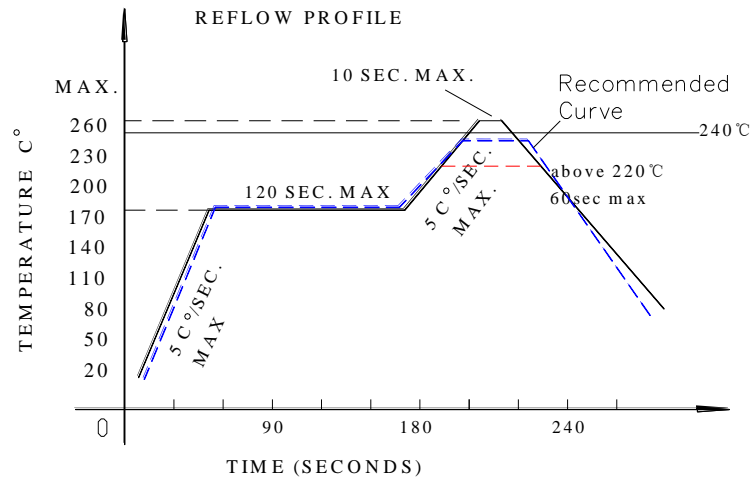

Reflow soldering curve

(Product is highest resistant to 260°C reflow but suggested the highest temperature of 240°C within)

■ Notes for reflow soldering :

1. No more than twice for reflow soldering.
2. To ensure the quality of our LEDs, we encapsulate them with silica gels. So please do not put pressure on the LEDs.
3. Please choose the right nozzle(try to learn from the plastic products parts) to avoid the damage to products due to the pressure.
4. Please put on the antistatic hand loop during the use. The worktable should be with antistatic finish. The equipments must be contacted with ground.

■ Handwork soldering:

1. During the soldering, the electronic soldering iron must be kept under the temperature of 300°C and the soldering time must not be beyond 3 seconds. No touch between the electronic soldering iron and colloid.
2. Handwork soldering is only allowed once. We won't take responsibility for more than that.
3. Avoid using sharp objects to compress products Colloidal Part directly.
4. Please put on the antistatic hand loop during the use. The worktable should be with antistatic finish. The equipments must be contacted with ground.