

# 2835R Series

Standard 2835 package to address retrofit applications

2835R Series is a complementary portfolio with optimized performance and bin construction for the retrofit space. With an industry standard footprint, it provides the perfect balance between performance and cost efficiency for a variety of applications.

## **FEATURES AND BENEFITS**

Flexible voltage configurations to comply with various different system solutions

Industry standard footprint for drop-in replacement designs

High maximum drive current to allow for reduction of LED count



# Part Number Nomenclature

Part numbers for the 2835R Series follow the convention below:

**L 1 2 8 – A A B B R C 3 5 0 0 D D D**

Where:

**A A** - designates nominal CCT (27=2700K, 30=3000K, 35=3500K, 40=4000K, 50=5000K, 57=5700K, 65=6500K)

**B B** - designates nominal CRI (70=70CRI, 75=75CRI, 80=80CRI and 90=90CRI)

**C** - designates voltage (A=3V, B=6V, C=9V, D=18V, E=36V, F=54V)

**D D D** - designates Lumileds internal code (0A1, 0B1, 0C1, etc.=shares the same base part)

Therefore, the following part number is used for a 2835R 3000K, 80CRI, 36V LED:

**L 1 2 8 – 3 0 8 0 R E 3 5 0 0 0 A 1**

## Lumen Maintenance

Please contact your local Sales Representative or Lumileds Technical Solutions Manager for more information about the long- term performance of this product.

## Environmental Compliance

Lumileds LLC is committed to providing environmentally friendly products to the solid-state lighting market. The 2835R Series is compliant to the European Union directives on the restriction of hazardous substances in electronic equipment, namely the RoHS Directive 2011/65/EU and REACH Regulation (EC) 1907/2006. Lumileds LLC will not intentionally add the following restricted materials to its products: lead, mercury, cadmium, hexavalent chromium, polybrominated biphenyls (PBB) or polybrominated diphenyl ethers (PBDE).

## Mass Production List of 2835R Series

Product	Product Number	CCT	Ra Min	Φ(lm) Min	Φ(lm) Typ	Φ(lm) Max	Test conditions
2835R 6V	L128-2770RB35000H1	2700	70	150	157	-	25°C, IF=150mA
	L128-3070RB35000H1	3000	70	155	162	-	
	L128-3570RB35000H1	3500	70	160	167	-	
	L128-4070RB35000H1	4000	70	165	172	-	
	L128-5070RB35000H1	5000	70	165	172	-	
	L128-5770RB35000H1	5700	70	165	172	-	
	L128-6570RB35000H1	6500	70	165	172	-	

### Notes:

- 1.Tolerance of Color Rendering Index:  $\pm 2$ .
- 2.Tolerance of Luminous flux:  $\pm 5\%$ .

### Absolute maximum ratings(Ta=25°C)

Parameter	Symbol	Value	Unit
<b>Power dissipation</b>	Pd	1280	mW
<b>Forward current</b>	IF	200	mA
<b>Operating temperature range</b>	Top	-40~+105	°C
<b>Storage temperature range</b>	Tstg	-40~+105	°C
<b>Heat resistance</b>	Rth	16	°C/W
<b>Junction temperature</b>	Tj	125	°C
<b>Electrostatic Discharge</b>	ESD	2000	V

## Electro-optical characteristics(Ta=25°C)

Parameter	Symbol	Min	Typ	Max	Unit	Test Condition
<b>Forward voltage</b>	Vf	5.8	-	6.4	V	IF=150mA
<b>Luminous flux</b>	Φ	150	-	-	lm	IF=150mA
<b>Viewing Angle</b>	2 θ 1/2	-	120	-	Deg	IF=150mA
<b>Color Index</b>	Ra	70	-	-	-	IF=150mA

### NOTES:

- \* The measurement of forward voltage maintains a tolerance of  $\pm 0.05V$ , flux maintains a tolerance of  $\pm 5\%$ .
- \* Ra measurement tolerance is  $\pm 2$ .
- \* Rth j-sp is the thermal resistance from LED junction to solder point on MCPCB with electrical power.
- \* the product is not designed to be used under reverse voltage.

## Reliability Test Items and Conditions

Test Items	Test condition	Time	Quantity	Failure Criteria
Reflow Soldering	Temp. :260°C/10sec.	6Min.	22pcs	0/22
Thermal Shock	-40~125C, 15min dwell, 10sec transfer	100Cycles	22pcs	0/22
High Temperature High Humidity life Test	85°C,85%RH, IF=150mA	1000Hrs.	10pcs	0/10
Low Temperature Storage	Ta=-40°C	1000Hrs.	10pcs	0/10
High Temperature Storage	Ta=105°C	1000Hrs.	10pcs	0/10
High Temperature Operation Life Test	Ta=85°C, IF =150mA.	1000Hrs.	10pcs	0/10

## Failure Criteria

Item	Symbol	Failure Criteria
Luminous Flux	Lm	$\geq 70\%$
Forward voltage	VF	$\pm 10\%$
Colour	CIE_X CIE_y	$\pm 0.01$

## Typical optical characteristics curves

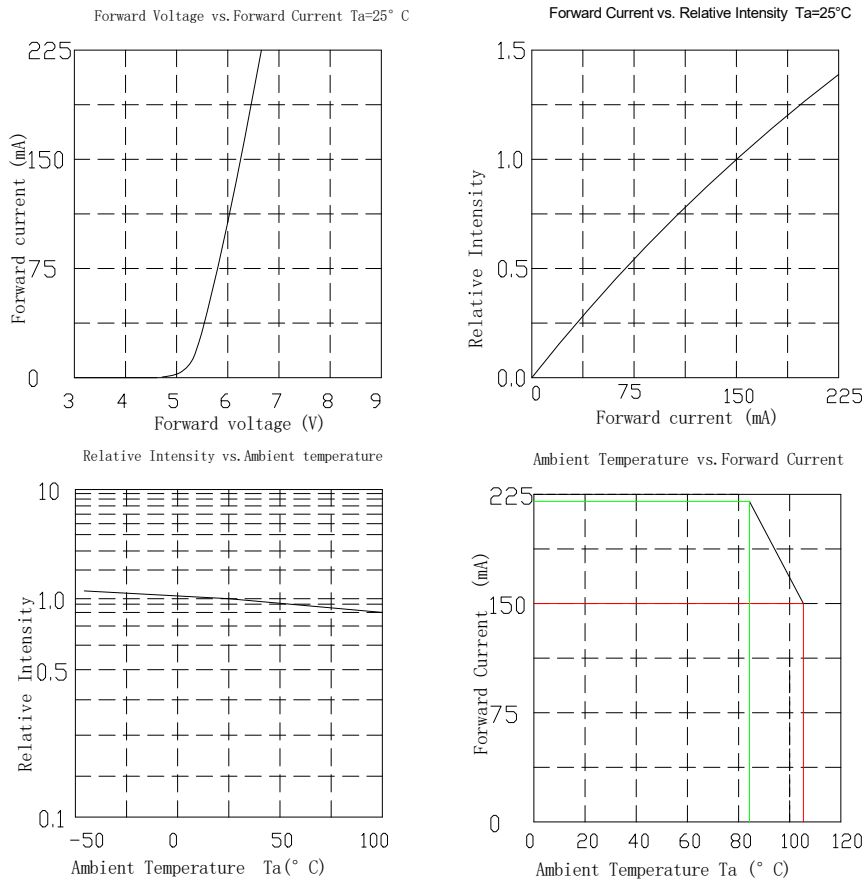

## Curves of beam angle and relative brightness

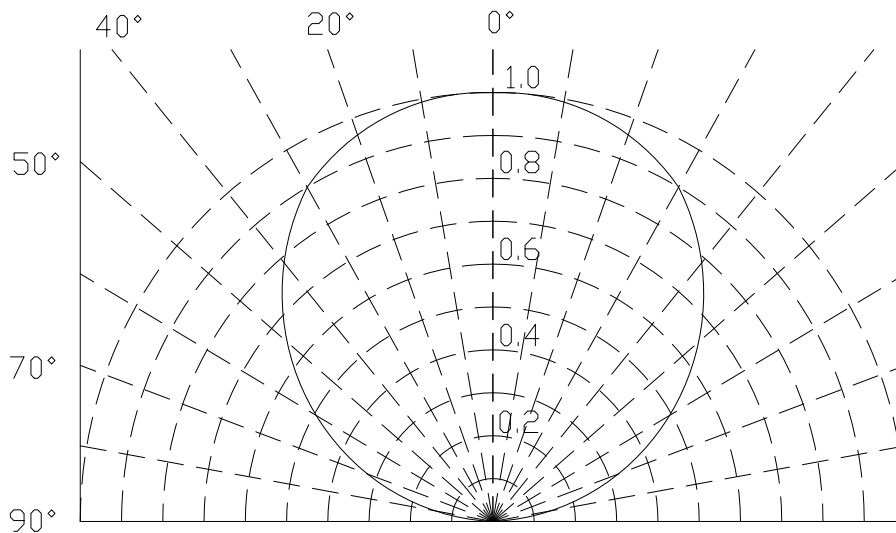

# life test:

Affect of  $T_j$  on Luminous Maintenance  
 ( $I_f=100mA$ )  
 (Dot line: Expected Life)

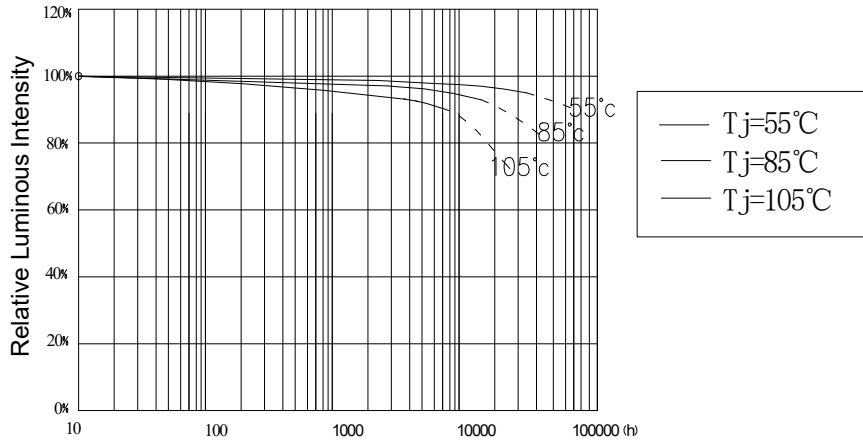

## Mechanical Dimensions: Unit (mm)

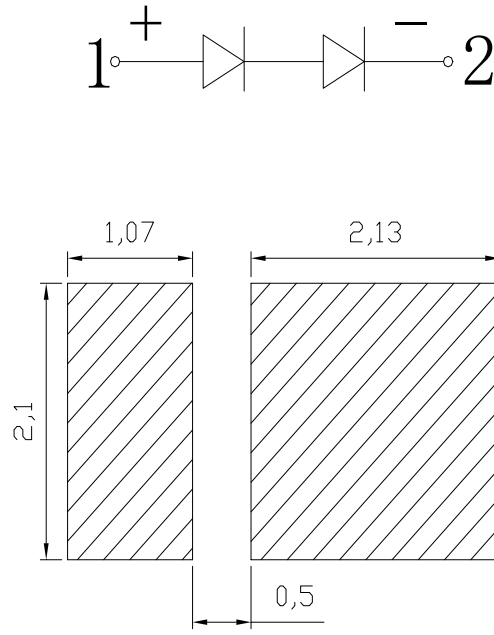
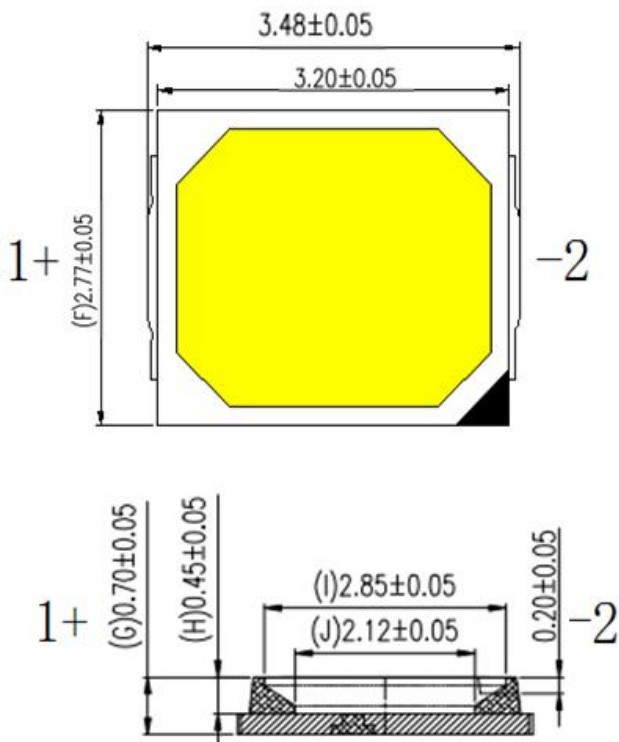

For reflow soldering

# Product Bin and Labeling Definitions

## Decoding Product Bin Labeling

In the manufacturing of semiconductor products, there are variations in performance around the average values given in the technical datasheet. For this reason, Lumileds bins LED components for luminous flux or radiometric power, color point, peak or dominant wavelength and forward voltage.

2835R Series LEDs are labeled using a 5-digit alphanumeric CAT code following the format below

Where:

### **A B C D E**

**A** - designates luminous flux bin (example: B=95 to 100 lumens, G=140 to 150 lumens)

**B C D** - designates correlated color bin (example: A27, A30, A35, A40, A50, A57, A65)

**E** - designates forward voltage bin (example: B=34.5 to 35.0V, J=38.0 to 38.5V)

Therefore, a 2835R LED with a lumen range of 95 to 100, color bin of A35 and a forward voltage range of 38.0 to 38.5V has the following CAT code:

**B A 3 5 J**



# Luminous Flux Bins

**Luminous flux bin definitions for 2835R Series at rated current, Ta=25°C .**

Product Number	Bin	Min	Max
L128-XX70RB35000H1	H	150	160
	J	160	170
	K	170	180

**Notes**

**Lumileds Maintains a tolerance of ±5% on luminous flux measurements**

# Forward Voltage Bins

**Forward voltage bin definitions for 2835R Series at rated current, Ta =25°C .**

Product Number	Bin	Min	Max
L128-XX70RB35000H1	B	5.8	6.0
	C	6.0	6.2
	D	6.2	6.4

# Color Bin Definition

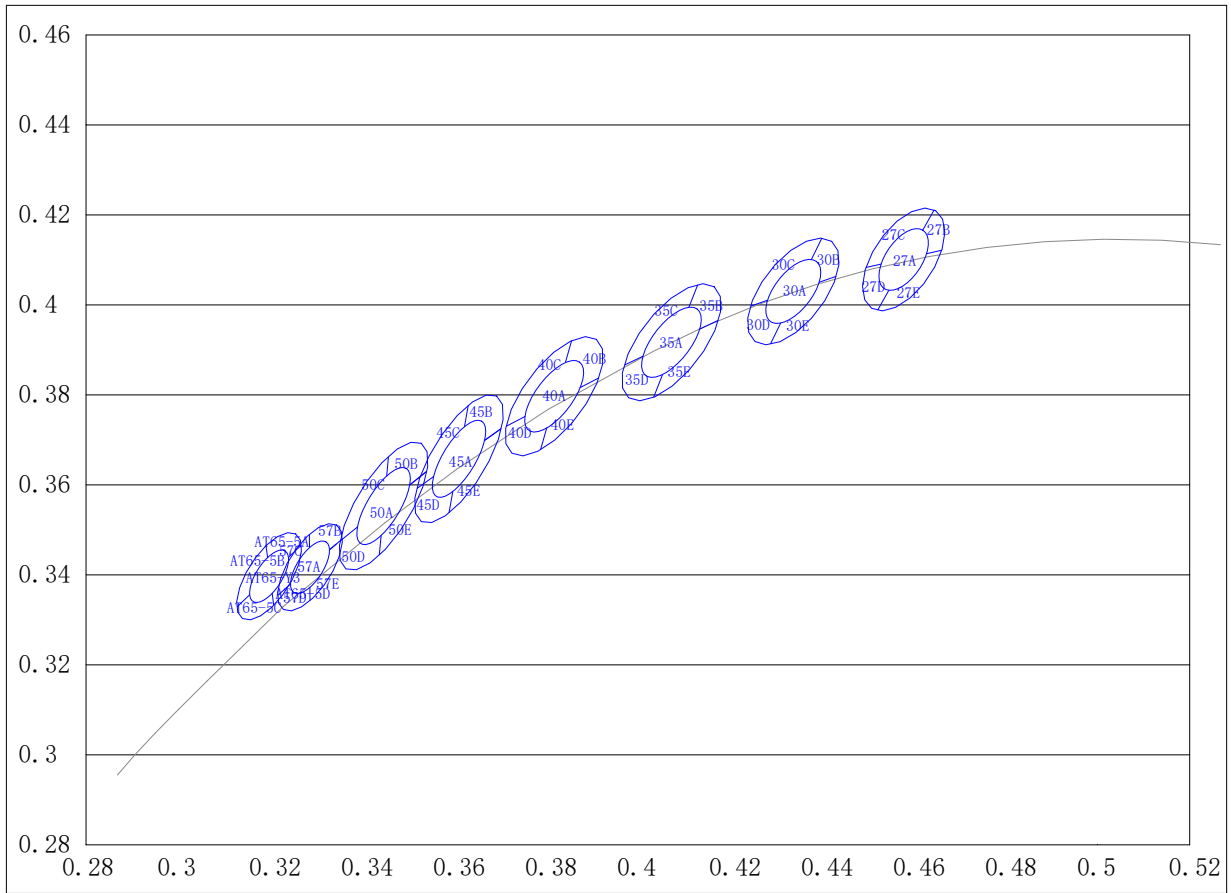

**Correlated color temperature bin definitions for 2835R Series at rated current,  
Ta=25°C**

CCT	Color space	Center X	Center Y	a	b	Rotation Angle
2700K	3-Step	0.4578	0.4101	0.00770000	0.00400000	57.28
	5-Step	0.4578	0.4101	0.01290000	0.00670000	57.28
3000K	3-Step	0.4338	0.403	0.00834624	0.00409845	53.16
	5-Step	0.4338	0.403	0.01391042	0.00683075	53.16
3500K	3-Step	0.4073	0.3917	0.00927100	0.00413900	52.96
	5-Step	0.4073	0.3917	0.01545200	0.00689900	52.96
4000K	3-Step	0.3818	0.3797	0.00938600	0.00403500	54
	5-Step	0.3818	0.3797	0.01564400	0.00672500	54
4500K	3-Step	0.3611	0.3658	0.00971000	0.00360000	59.62
	5-Step	0.3611	0.3658	0.01618300	0.00600000	59.62
5000K	3-Step	0.3447	0.3553	0.00971000	0.00360000	59.62
	5-Step	0.3447	0.3553	0.01618300	0.00600000	59.62
5700K	3-Step	0.3287	0.3417	0.00661700	0.00285500	58.38
	5-Step	0.3287	0.3417	0.01102900	0.00475800	58.38
6500K	3-Step	0.3198	0.3397	0.0072792	0.0031398	58.38
	5-Step	0.3198	0.3397	0.012132	0.005233	58.38

bin Colde	27A/B/C/D/E		30A/B/C/D/E		35A/B/C/D/E		40A/B/C/D/E	
CCT	2700K		3000K		3500K		4000K	
#	x	y	x	y	x	y	x	y
1	0.4813	0.4319	0.4562	0.426	0.4299	0.4165	0.4005	0.4044
2	0.4688	0.429	0.4431	0.4213	0.4148	0.409	0.3866	0.3955
3	0.4562	0.426	0.4299	0.4165	0.3996	0.4015	0.3726	0.3866
4	0.4468	0.4077	0.4223	0.399	0.3943	0.3853	0.3693	0.3719
5	0.4373	0.3893	0.4147	0.3814	0.3889	0.369	0.366	0.3572
6	0.4483	0.3919	0.426	0.3854	0.4018	0.3752	0.3779	0.3644
7	0.4593	0.3944	0.4373	0.3893	0.4147	0.3814	0.3897	0.3716
8	0.4703	0.4132	0.4468	0.4077	0.4223	0.399	0.3943	0.3853

bin Colde	50A/B/C/D/E		57A/B/C/D/E		AT65-Y3/AT65-Y3-5A/B/C/D	
CCT	5000K		5700K		6500K	
#	x	y	x	y	x	y
1	0.3587	0.3792	0.3377	0.3617	0.3281	0.3597
2	0.346	0.3687	0.3285	0.3533	0.3187	0.3503
3	0.3333	0.3583	0.3194	0.345	0.3093	0.3409
4	0.3331	0.3458	0.3201	0.334	0.3113	0.3314
5	0.3329	0.3333	0.3208	0.3231	0.3134	0.3219
6	0.3435	0.3416	0.3287	0.33	0.3213	0.3296
7	0.3541	0.35	0.3367	0.337	0.3296	0.3376
8	0.3564	0.365	0.3372	0.3493	0.3288	0.3486

**Notes**

Tester tolerance: ±0.01 in x and y coordinates

## Requirements for application and reflow soldering :

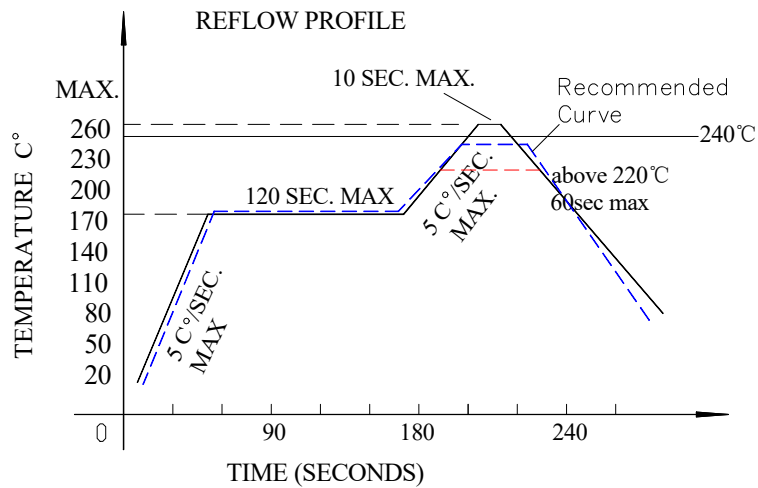

Reflow soldering curve

(Product is highest resistant to 260°C reflow but suggested the highest temperature of 240°C within)

### ■ Notes for reflow soldering :

1. No more than twice for reflow soldering.
2. To ensure the quality of our LEDs, we encapsulate them with silica gels. So please do not put pressure on the LEDs.
3. Please choose the right nozzle(try to learn from the plastic products parts) to avoid the damage to products due to the pressure.
4. Please put on the antistatic hand loop during the use. The worktable should be with antistatic finish. The equipments must be contacted with ground.

### ■ Handwork soldering:

1. During the soldering, the electronic soldering iron must be kept under the temperature of 300°C and the soldering time must not be beyond 3 seconds. No touch between the electronic soldering iron and colloid.
2. Handwork soldering is only allowed once. We won't take responsibility for more than that.
3. Avoid using sharp objects to compress products Colloidal Part directly.
4. Please put on the antistatic hand loop during the use. The worktable should be with antistatic finish. The equipments must be contacted with ground.