

Lumileds 2835R Series



Lumileds 2835R Series is a complementary portfolio with optimized performance and bin construction for the retrofit space. With an industry standard footprint, it provides the perfect balance between performance and cost efficiency for a variety of applications.

CHARACTERISTICS

- Flexible voltage configurations to comply with various different system solutions
- Industry standard footprint for drop-in replacement designs
- High maximum drive current to allow for reduction of LED count

Table of Contents

Table of Contents	2
Part Number Nomenclature	3
Lumen Maintenance	3
Environmental Compliance	3
Mass Production List of 2835R Series	4
Absolute Maximum Ratings (Ta=25°C)	4
Electro-optical Characteristics (Ta=25°C)	5
Reliability Test Items And Conditions	6
Failure Criteria	6
Typical Optical Characteristics Curves	7
Mechanical Dimensions	8
Product Bin and Labeling Definitions	9
Decoding Product Bin Labeling	9
Luminous Flux Bins	9
Forward Voltage Bins	9
Color Bin Definition	10
Color Bin Definition.....	11
Requirements for Application and Reflow Soldering	12
About Lumileds	13

Part Number Nomenclature

Part numbers for the 2835R Series follow the convention below:

L 1 2 8 – A A B B R C 3 5 0 0 D D D

Where:

A A - designates nominal CCT (27=2700K, 30=3000K, 35=3500K, 40=4000K, 50=5000K, 57=5700K, 65=6500K)

B B - designates nominal CRI (70=70CRI, 75=75CRI, 80=80CRI and 90=90CRI)

C - designates voltage (A=3V, B=6V, C=9V, G=12V, D=18V, E=36V, F=54V)

D D D - designates Lumileds internal code (0A1, 0B1, 0C1, etc.=shares the same base part)

Therefore, the following part number is used for a 2835R 3000K, 80CRI, 36V LED:

L 1 2 8 – 3 0 8 0 R E 3 5 0 0 0 A 1

Lumen Maintenance

Please contact your local Sales Representative or Lumileds Technical Solutions Manager for more information about the long- term performance of this product.

Environmental Compliance

Lumileds LLC is committed to providing environmentally friendly products to the solid-state lighting market. The 2835R Series is compliant to the European Union directives on the restriction of hazardous substances in electronic equipment, namely the RoHS Directive 2011/65/EU and REACH Regulation (EC) 1907/2006. Lumileds LLC will not intentionally add the following restricted materials to its products: lead, mercury, cadmium, hexavalent chromium, polybrominated biphenyls (PBB) or polybrominated diphenyl ethers (PBDE).

Mass Production List of 2835R Series

Product	Product Number	CCT	Ra Min	Φ (lm) Min	Φ (lm) Typ	Test conditions
2835R 6V	L128-2780RB35000M2	2700	80	118	125	25°C, IF=150mA
	L128-3080RB35000M2	3000	80	120	128	
	L128-3580RB35000M2	3500	80	122	130	
	L128-4080RB35000M2	4000	80	125	133	
	L128-5080RB35000M2	5000	80	125	133	
	L128-5780RB35000M2	5700	80	125	133	
	L128-6580RB35000M2	6500	80	125	133	

Notes:

- 1.Tolerance of Color Rendering Index: ± 2 .
- 2.Tolerance of Luminous flux: $\pm 5\%$.

Absolute Maximum Ratings (Ta=25°C)

Parameter	Symbol	Value	Unit	Test Condition
Power dissipation	Pd	990	mW	-
Forward current	IF	150	mA	-
Pulsed Forward Current	IPF	200	mA	Duty 1/10,pulse width 10ms
Operating temperature range	Top	-40~+105	°C	-
Storage temperature range	Tstg	-40~+105	°C	-
Heatresistance	Rth	18	°C/W	-
Junction temperature	Tj	125	°C	-
Electrostatic Discharge	ESD	2000	V	-

Electro-optical Characteristics (Ta=25°C)

Parameter	Symbol	Min	Typ	Max	Unit	Test Condition
Forward voltage	Vf	5.8	-	6.6	V	IF=150mA
Luminous flux	Φ	118	-	-	lm	IF=150mA
Viewing Angle	2 θ 1/2	-	120	-	Deg	IF=150mA
Color Index	Ra	80	-	-	-	IF=150mA

NOTES:

* The measurement of forward voltage maintains a tolerance of $\pm 0.05V$, flux maintains a tolerance of $\pm 5\%$.

* Ra measurement tolerance is ± 2 .

* Rth j-sp is the thermal resistance from LED junction to solder point on MCPCB with electrical power.

* the product is not designed to be used under reverse voltage.

Reliability Test Items And Conditions

Test Items	Test condition	Time	Quantity	Ac/Re
Reflow Soldering	Temp. :260°C/10sec.	6Min.	22pcs	0/22
Thermal Shock	-40~125C, 15min dwell, 10sec transfer	100Cycles	22pcs	0/22
High Temperature High Humidity life Test	85°C,85%RH, IF=150mA	1000Hrs.	10pcs	0/10
Low Temperature Storage	Ta=-40°C	1000Hrs.	10pcs	0/10
High Temperature Storage	Ta=105°C	1000Hrs.	10pcs	0/10
High Temperature Operation Life Test	Ta=85°C, IF =150mA.	1000Hrs.	10pcs	0/10

Failure Criteria

Item	Symbol	Failure Criteria
Luminous Flux	Lm	$\geq 70\%$
Forward voltage	VF	$\pm 10\%$
Colour	CIE_X CIE_y	± 0.01

Typical Optical Characteristics Curves

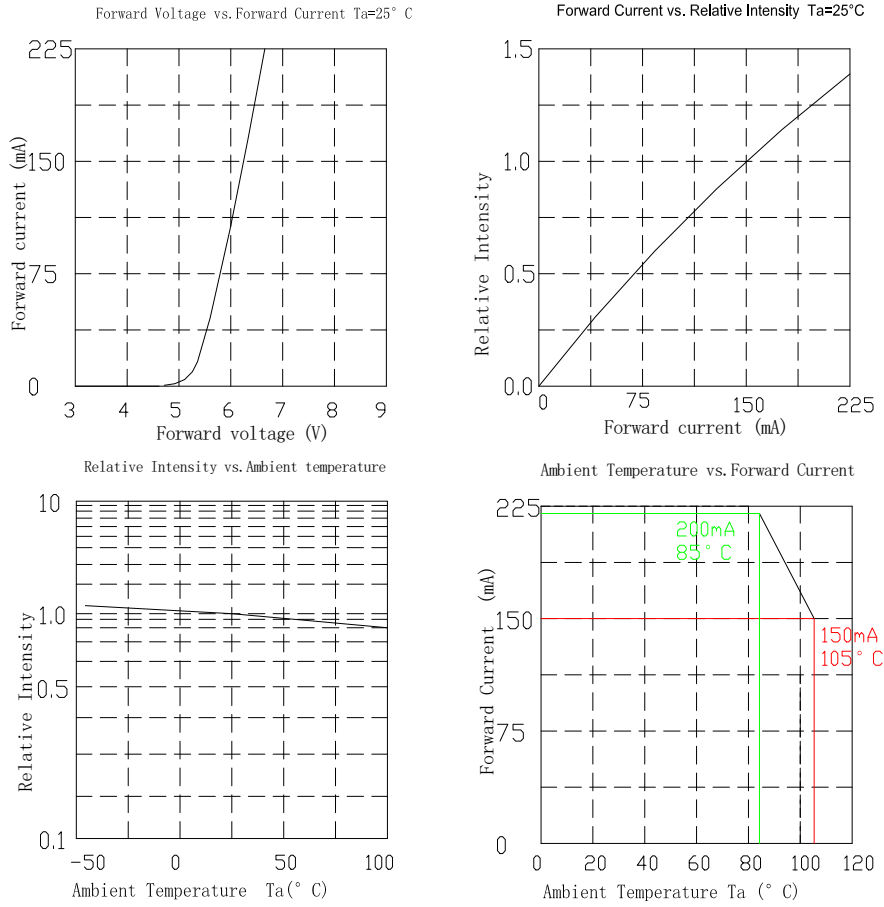

Curves of beam angle and relative brightness

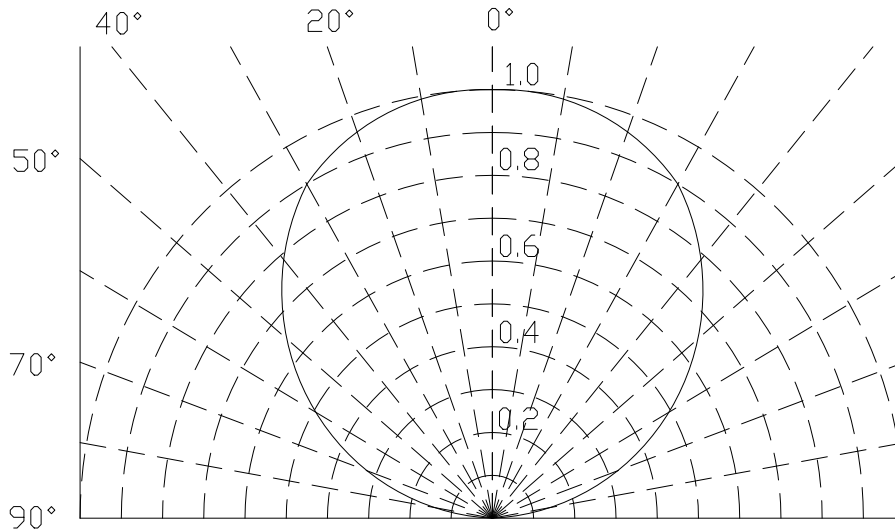

life test:

Affect of T_j on Luminous Maintenance
 ($I_f=150\text{mA}$)
 (Dot line: Expected Life)

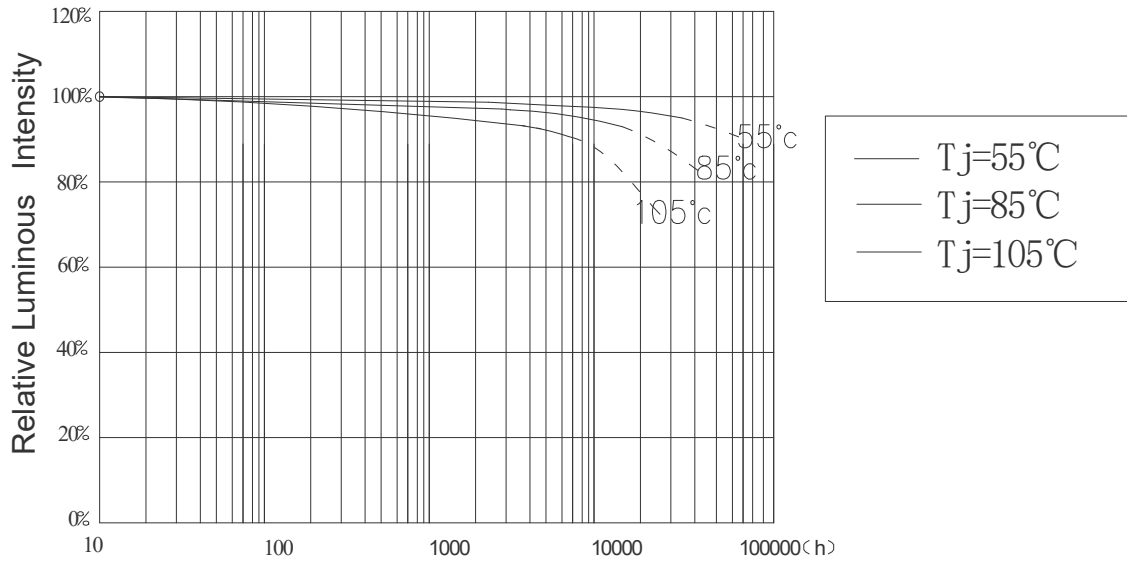

Mechanical Dimensions

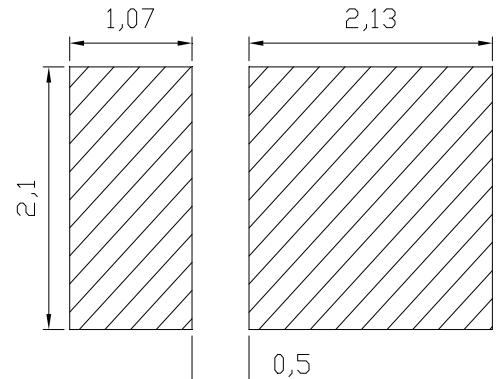
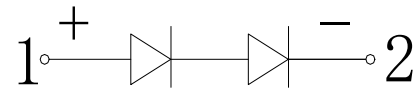
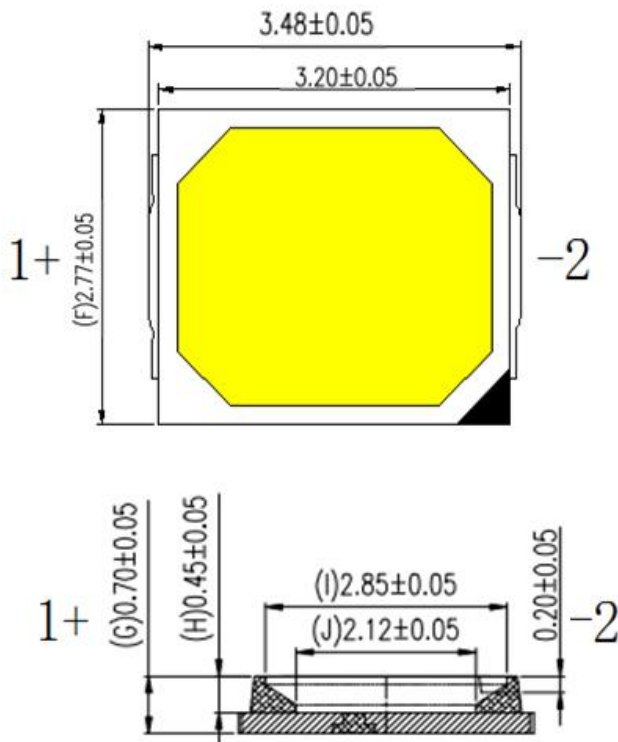

For reflow soldering

Product Bin and Labeling Definitions

Decoding Product Bin Labeling

In the manufacturing of semiconductor products, there are variations in performance around the average values given in the technical datasheet. For this reason, Lumileds bins LED components for luminous flux or radiometric power, color point, peak or dominant wavelength and forward voltage.

2835R Series LEDs are labeled using a 5-digit alphanumeric CAT code following the format below

Where:

A B C D E

A - designates luminous flux bin (example: B=95 to 100 lumens, G=140 to 150 lumens)

B C D - designates correlated color bin (example: A27, A30, A35, A40, A50, A57, A65)

E - designates forward voltage bin (example: B=34.5 to 35.0V, J=38.0 to 38.5V)

Therefore, a 2835R LED with a lumen range of 95 to 100, color bin of A35 and a forward voltage range of 38.0 to 38.5V has the following CAT code:

B A 3 5 J

Luminous Flux Bins

Luminous flux bin definitions for 2835R Series at rated current, Ta=25°C .

Product Number	Bin	Min	Max
L128-XX80RB35000M2	D	110	120
	E	120	130
	F	130	140
	H	140	150

Notes

Lumileds Maintains a tolerance of $\pm 5\%$ on luminous flux measurements

Forward Voltage Bins

Forward voltage bin definitions for 2835R Series at rated current, Ta=25°C .

Product Number	Bin	Min	Max
L128-XX80RB35000M2	A	5.6	5.8
	B	5.8	6.0
	C	6.0	6.2
	D	6.2	6.4
	E	6.4	6.6

Color Bin Definition

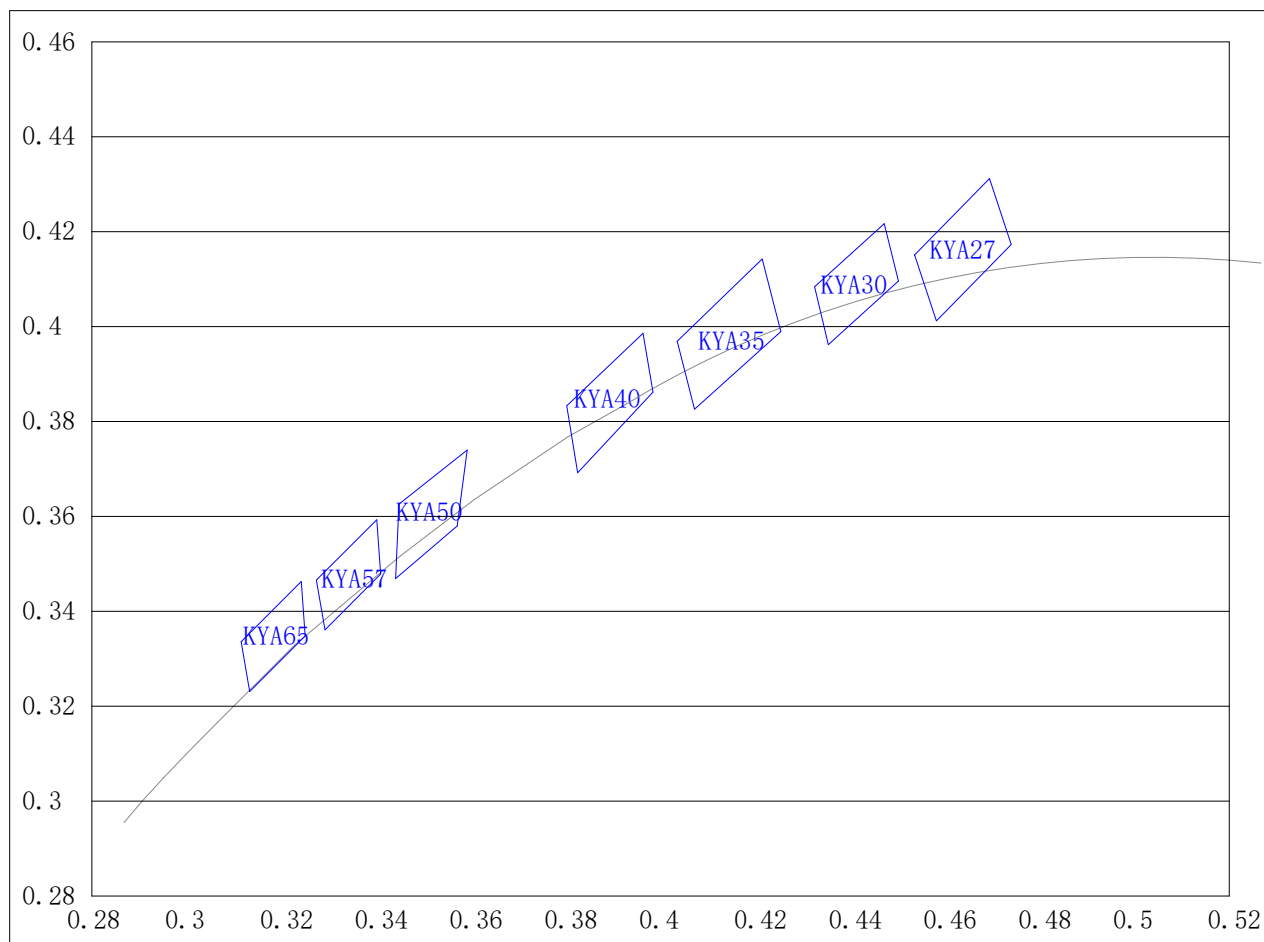

Correlated color temperature bin definitions for 2835R Series at rated current, $T_a=25^{\circ}\text{C}$

色区	KYA27		色区	KYA30		色区	KYA35		色区	KYA40	
色温	2700K		色温	3000K		色温	3500K		色温	4000K	
中心点	X	Y	中心点	X	Y	中心点	X	Y	中心点	X	Y
	0.4638	0.4162		0.4413	0.4089		0.4144	0.398		0.3893	0.3844
坐标	0.4582	0.4012	坐标	0.4354	0.3962	坐标	0.4254	0.399	坐标	0.3825	0.3692
	0.4536	0.4151		0.4325	0.4084		0.4214	0.4142		0.3802	0.3833
	0.4694	0.4312		0.4472	0.4217		0.4035	0.3969		0.3963	0.3986
	0.474	0.4173		0.4502	0.4096		0.4072	0.3826		0.3984	0.3862

色区	KYA50		色区	KYA57		色区	KYA65	
色温	5000K		色温	5700K		色温	6500K	
中心点	X	Y	中心点	X	Y	中心点	X	Y
	0.3513	0.3604		0.3344	0.3475		0.3185	0.3345
坐标	0.3441	0.3469	坐标	0.3292	0.3361	坐标	0.3133	0.3231
	0.3448	0.3626		0.3274	0.3466		0.3115	0.3336
	0.3592	0.374		0.3401	0.3593		0.3242	0.3463
	0.3571	0.358		0.3409	0.3478		0.325	0.3348

Notes

Tester tolerance: ± 0.01 in x and y coordinates

Requirements for Application and Reflow Soldering

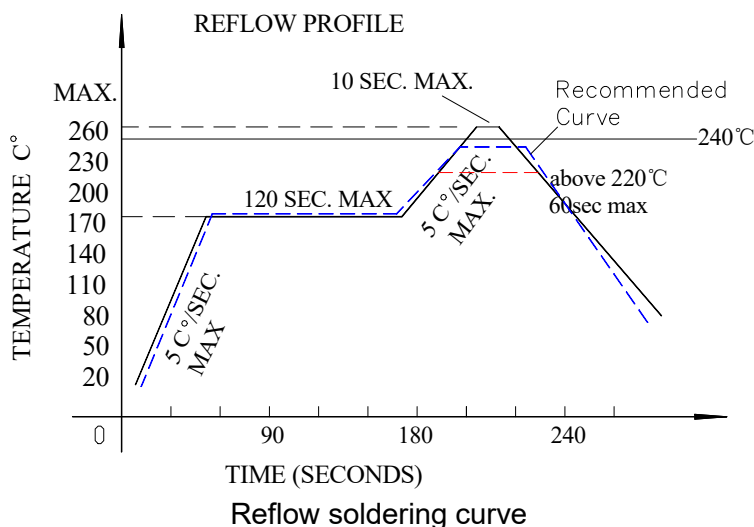

(Product is highest resistant to 260°C reflow but suggested the highest temperature of 240°C within)

■ Notes for reflow soldering :

1. No more than twice for reflow soldering.
2. To ensure the quality of our LEDs, we encapsulate them with silica gels. So please do not put pressure on the LEDs.
3. Please choose the right nozzle(try to learn from the plastic products parts) to avoid the damage to products due to the pressure.
4. Please put on the antistatic hand loop during the use. The worktable should be with antistatic finish. The equipments must be contacted with ground.

■ Handwork soldering:

1. During the soldering, the electronic soldering iron must be kept under the temperature of 300°C and the soldering time must not be beyond 3 seconds. No touch between the electronic soldering iron and colloid.
2. Handwork soldering is only allowed once. We won't take responsibility for more than that.
3. Avoid using sharp objects to compress products Colloidal Part directly.
4. Please put on the antistatic hand loop during the use. The worktable should be with antistatic finish. The equipments must be contacted with ground.

About Lumileds

Companies developing automotive, mobile, IoT and illumination lighting applications need a partner who can collaborate with them to push the boundaries of light. With over 100 years of inventions and industry firsts, Lumileds is a global lighting solutions company that helps customers around the world deliver differentiated solutions to gain and maintain a competitive edge. As the inventor of Xenon technology, a pioneer in halogen lighting and the leader in high performance LEDs, Lumileds builds innovation, quality and reliability into its technology, products and every customer engagement. Together with its customers, Lumileds is making the world better, safer, more beautiful—with light.

To learn more about our lighting solutions, visit lumileds.com

Lumileds 2835R Product Datasheet

©2022 Lumileds Holding B.V. All rights reserved.

Neither Lumileds Holding B.V. nor its affiliates shall be liable for any kind of loss of data or any other damages, direct, indirect or consequential, resulting from the use of the provided information and data. Although Lumileds Holding B.V. and/or its affiliates have attempted to provide the most accurate information and data, the materials and services information and data are provided “as is,” and neither Lumileds Holding B.V. nor its affiliates warrants or guarantees the contents and correctness of the provided information and data. Lumileds Holding B.V. and its affiliates reserve the right to make changes without notice. You as user agree to this disclaimer and user agreement with the download or use of the provided materials, information and data. A listing of Lumileds product/patent coverage may be accessed at lumileds.com/patents.